

PWM Power Unit

The device allows continuous power control for lamps, LEDs or inductive loads.

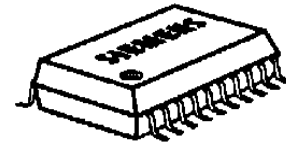

- Highside switch (Bootstrap)
- Overtemperature protection
- Short circuit / overload protection through pulse width reduction and overload shutdown
- Load dump protection
- Undervoltage and overvoltage shutdown with auto-restart and hysteresis
- Reverse battery protection ¹⁾
- Timing frequency adjustable
- Controlled switching rise and fall times
- Maximum current internally limited
- Protection against loss of GND ²⁾
- Electrostatic discharge (ESD) protection
- Package: P-DSO-20-6 (SMD)

Note: Switching frequency is programmed with an external capacitor

Type	Ordering Code	Marking	Package
BTS730	Q67060-S7007-A2	-	P-DSO-20-6

Maximum Ratings

Parameter	Symbol	Values	Unit
Active overvoltage protection	$V_{bb(AZ)}$	>40	V
Short circuit current	I_{SC}	self-limited	-
Input current (DC)	I_{Ct}	2	mA
Pin1 (C_t) and pin19 (V_C)	I_{VC}	2	mA
Operating temperature range	T_j	-40...+150	°C
Storage temperature range	T_{stg}	-50...+150	
Power dissipation ³⁾ $T_a=25^\circ\text{C}$	P_{tot}	3	W
		$T_a=85^\circ\text{C}$	2
Thermal resistance chip-case ³⁾	$R_{th JC}$	≤35	K/W
		chip-ambient	$R_{th JA}$
Electrostatic discharge capability (ESD) (Human Body Model) acc. MIL-STD883D, method 3015.7 and ESD assn. std. S5.1-1993; R=1.5KΩ; C=100pF	V_{ESD}	≤ 1	kV

¹⁾ With 150Ω resistor in signal GND connection.

²⁾ Potential between signal GND and load GND >0.5V

³⁾ Device on 50mm×50mm×1.5mm epoxy PCB FR4 with 6 cm² (one layer, 70μm thick) copper area for V_{bb} connection, PCB is vertical without air blowing.

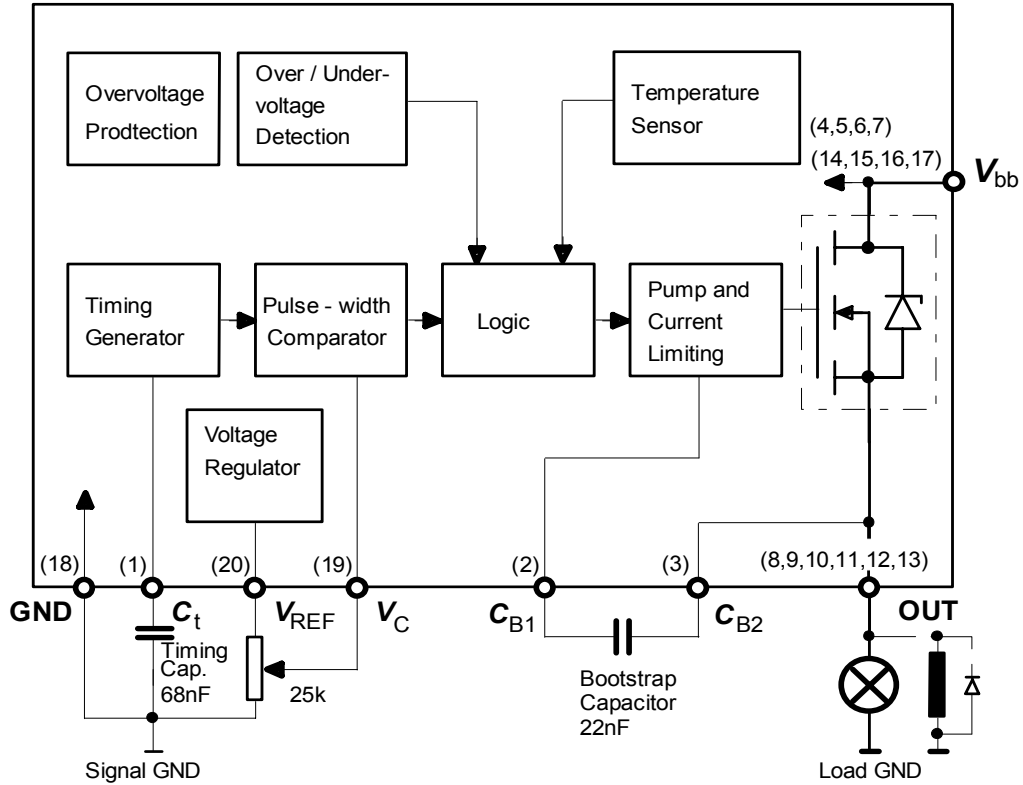
Block Diagram

Pin Definitions and Functions

Pin	Symbol	Funktions
1	C_t	Timing capacitor for frequency
2	C_{B1}	Bootstrap capacitor
3	C_{B2}	
4,5,6,7 14,15,16,17	V_{bb}	Supply voltage (Leadframe connected)
8,9,10 11,12,13	OUT	Output
18	GND	Ground
19	V_C	Voltage for PWM-Control
20	V_{REF}	Reference Voltage

Pin Configuration (top view)

C_t	1	20	V_{REF}
C_{B1}	2	19	V_C
C_{B2}	3	18	GND
V_{bb}	4	17	V_{bb}
V_{bb}	5	16	V_{bb}
V_{bb}	6	15	V_{bb}
V_{bb}	7	14	V_{bb}
OUT	8	13	OUT
OUT	9	12	OUT
OUT	10	11	OUT

Electrical Characteristics

 at $T_C = 25\text{ }^\circ\text{C}$, $V_{bb} = 12\text{ V}$, unless otherwise specified. $C_{\text{Bootstrap}} = 22\text{ nF}$

Parameter	Symbol	Values			Unit
		min.	typ.	max.	
On-state resistance $I_L=3\text{ A}$, $V_{bb}=12\text{ V}$	R_{ON}	-	-	70	m Ω
Operating voltage $T_C = -40 \dots +150\text{ }^\circ\text{C}$	V_{bb}	5.9 ¹⁾	-	16.9 ²⁾	V
Nominal current, calculated value ISO-standard: $V_{bb}-V_{\text{OUT}} \leq 0.5\text{ V}$, $T_C = 85\text{ }^\circ\text{C}$	$I_L\text{-ISO}$	3	-	-	A
Load current limit $V_{bb}-V_{\text{OUT}} > 1\text{ V}$, $T_C = -40 \dots +150\text{ }^\circ\text{C}$	I_{LLim}	-	20	-	A
Undervoltage shutdown $I_L = 3\text{ A}$, $T_C = -40 \dots +150\text{ }^\circ\text{C}$	$V_{bb(\text{LOW})}$	3	4.2	5.4	V
Overvoltage shutdown $I_L = 3\text{ A}$, $T_C = -40 \dots +150\text{ }^\circ\text{C}$	$V_{bb(\text{HI})}$	17	18	19	V
Max.output voltage (RMS) $I_L = 3\text{ A}$, $V_{bb} > 12\text{ V}$ $T_C = -40 \dots +150\text{ }^\circ\text{C}$	V_{RMSmax}	12	-	14	V
Reference voltage $I_{\text{REF}} = 10\text{ mA}$, $T_C = -40 \dots +150\text{ }^\circ\text{C}$	V_{REF}	2	-	3	V
Reference current pin 18 (GND) to pin 20 (V_{REF}) short	I_{REF}	-	150	-	mA
Internal current consumption during operation, measured in PWM gap $T_C = -40 \dots +150\text{ }^\circ\text{C}$	I_{R}	-	-	5	mA
Bootstrap voltage, pin 2 (C_{B1}) to pin 3 (C_{B2}) $V_{bb} = 12\text{ V}$, $T_C = -40 \dots +150\text{ }^\circ\text{C}$	V_{B}	-	10	-	V
PWM frequency $T_C = -40 \dots +150\text{ }^\circ\text{C}$, $C_t = 68\text{ nF}$	f_{PWM}	50	-	100	Hz
Max. pulse duty factor $I_L = 3\text{ A}$, $V_C=0\text{ V}$, (50% V_{OUT})	D_{imax}	95	98	-	%
Min. pulse duty factor $I_L = 3\text{ A}$, $V_C=0\text{ V}$, (50% V_{OUT})	D_{imin}	3	8	14	%
Slew rate "on" 10 ... 90% I_{OUT}	$du/dt_{(\text{on})}$	20	-	120	mV/ μs
Slew rate "off" 90 ... 10% I_{OUT}	$du/dt_{(\text{off})}$	20	-	120	mV/ μs
Thermal overload trip temperature	T_j	150	-	-	$^\circ\text{C}$

¹⁾ **Note:** undervoltage shutdown

²⁾ **Note:** overvoltage shutdown

Circuits

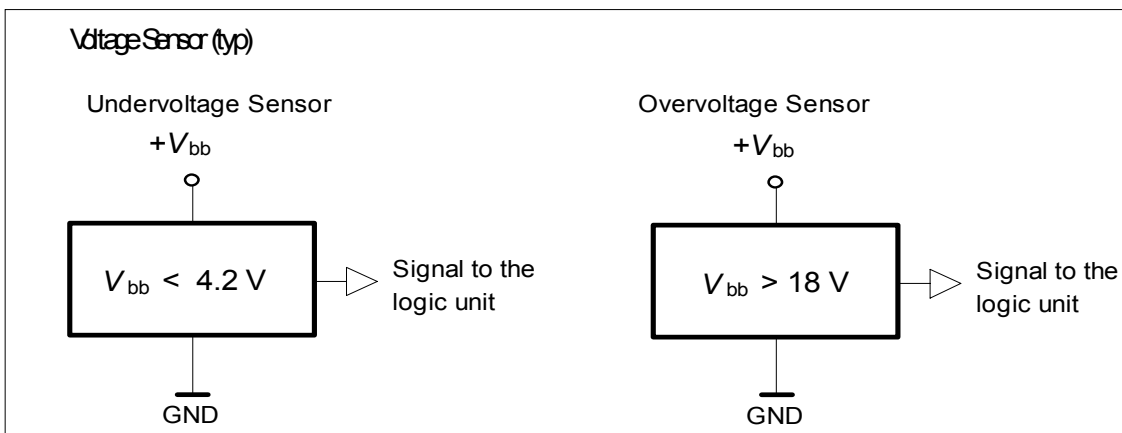
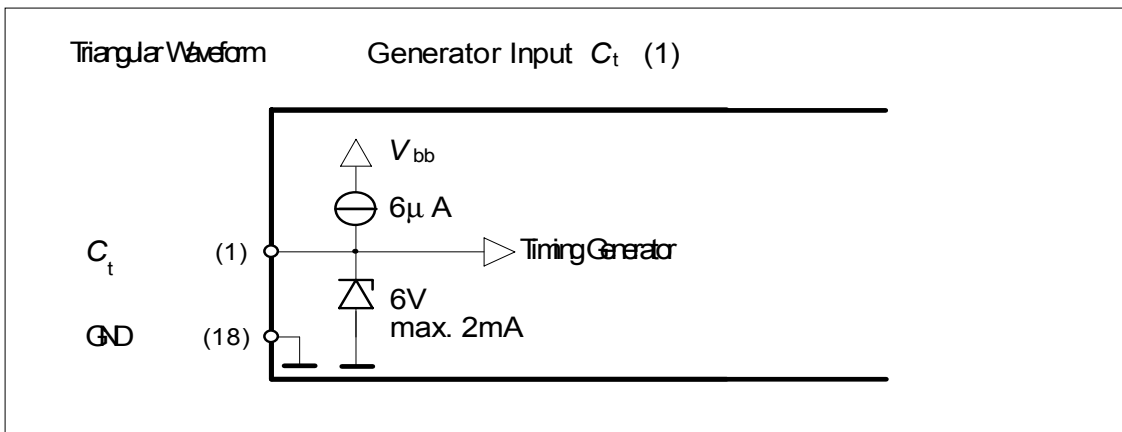
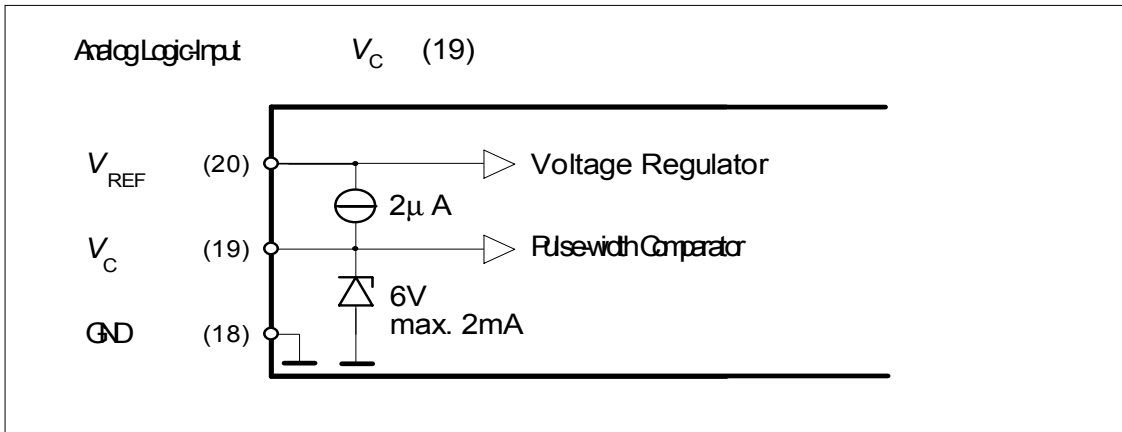

Application Note

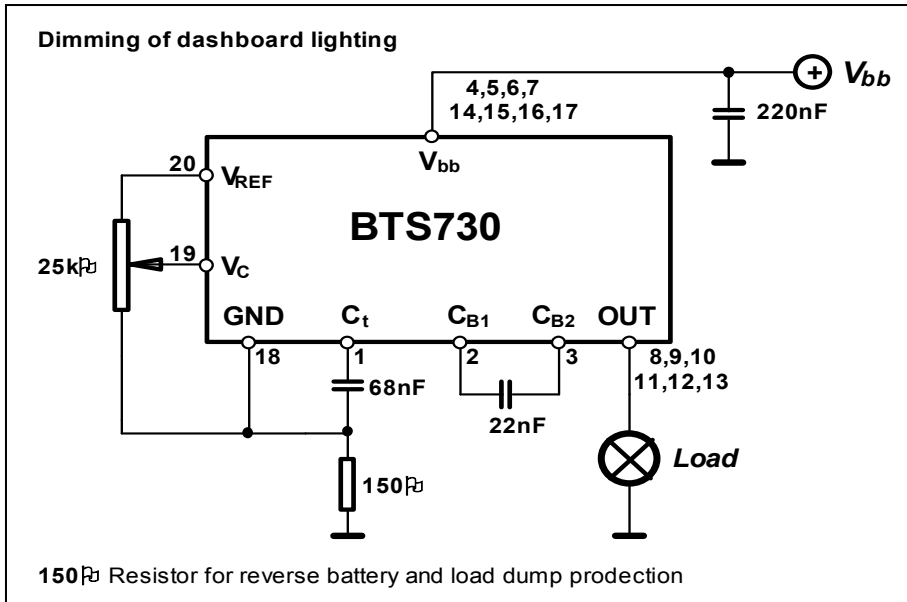

Package Outline P-DSO-20-6

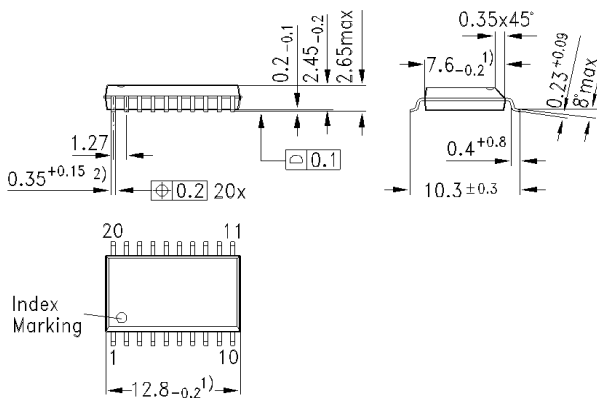

Dimensions in mm

